

SMART SHAFT GROUNDING

Smart CDR®

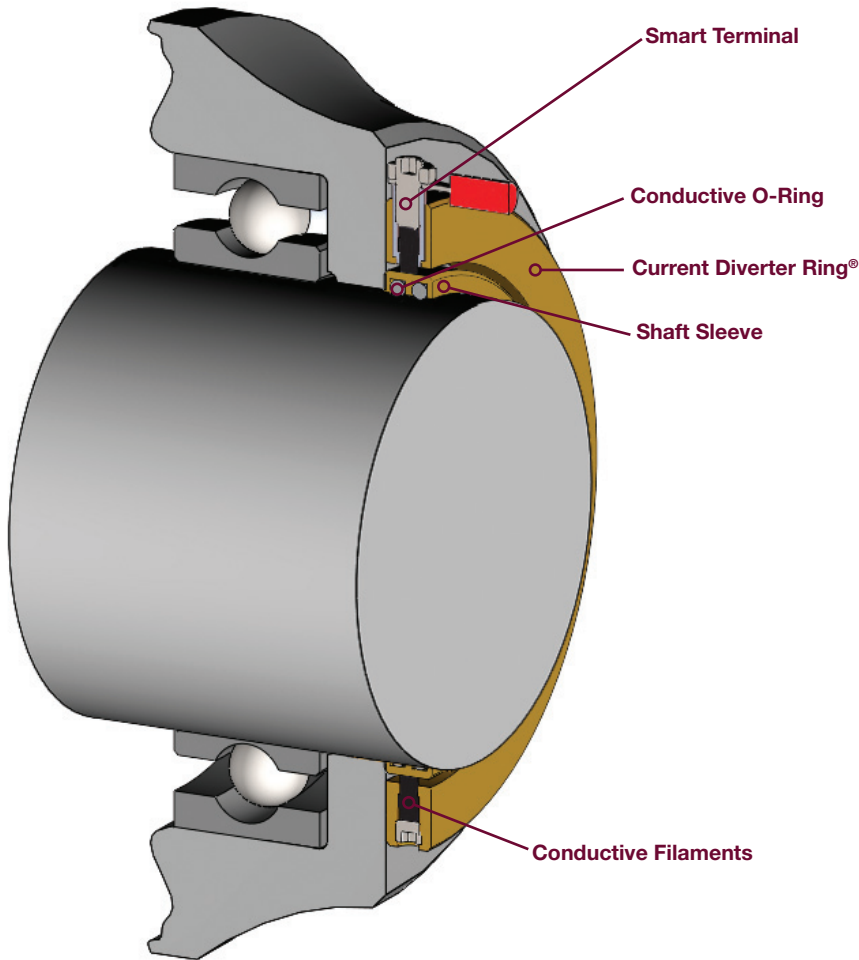

Smart CDR Features:

Smart Terminal - connects to the Smart Ground Monitor to provide condition monitoring

Conductive Filaments - provide a path to ground for shaft currents, away from the bearings

Shaft Sleeve - promotes premium grounding performance through consistent contact with conductive filaments; prevents conduction inhibiting oxidation from forming on the shaft

Conductive O-Rings - maintain conductivity for shaft currents and drives shaft sleeve

SMART CDR TECHNICAL DATA

A premium shaft grounding solution that uses proprietary conductive filaments and maintenance free shaft sleeve to divert harmful shaft currents away from the bearings to ground.

Standard Material: Bearing Bronze

Movement: Axial- 0.13 mm [0.005 in] | Radial- 0.64 mm [0.025 in] Consult Inpro/Seal engineering for shaft movement outside limits shown.

Temperature (Elastomers): Conductive O-Ring: Conductive Silicone- -65°C [-85°F] – 232°C [450°F]

Speed: 10,000 SFPM Consult Inpro/Seal engineering for speeds exceeding 6,000 SFPM.

Shaft Size: 15.88 mm [0.625 in] – 508 mm [20 in] Consult engineering for shaft sizes above 203.2 mm [8 in]

Mounting Configurations: Press-In, Clip-On, Side-Mount, Epoxy, Flexbracket, Bolt-Through

Standard Overall Length: 8.89 mm [0.350 in]

* Consult Inpro/Seal engineering for operating conditions outside limits shown above



www.inpro-seal.com | info@inpro-seal.com



© 2019 Dover Precision Components. All rights reserved. | d14.017.1-OC19