

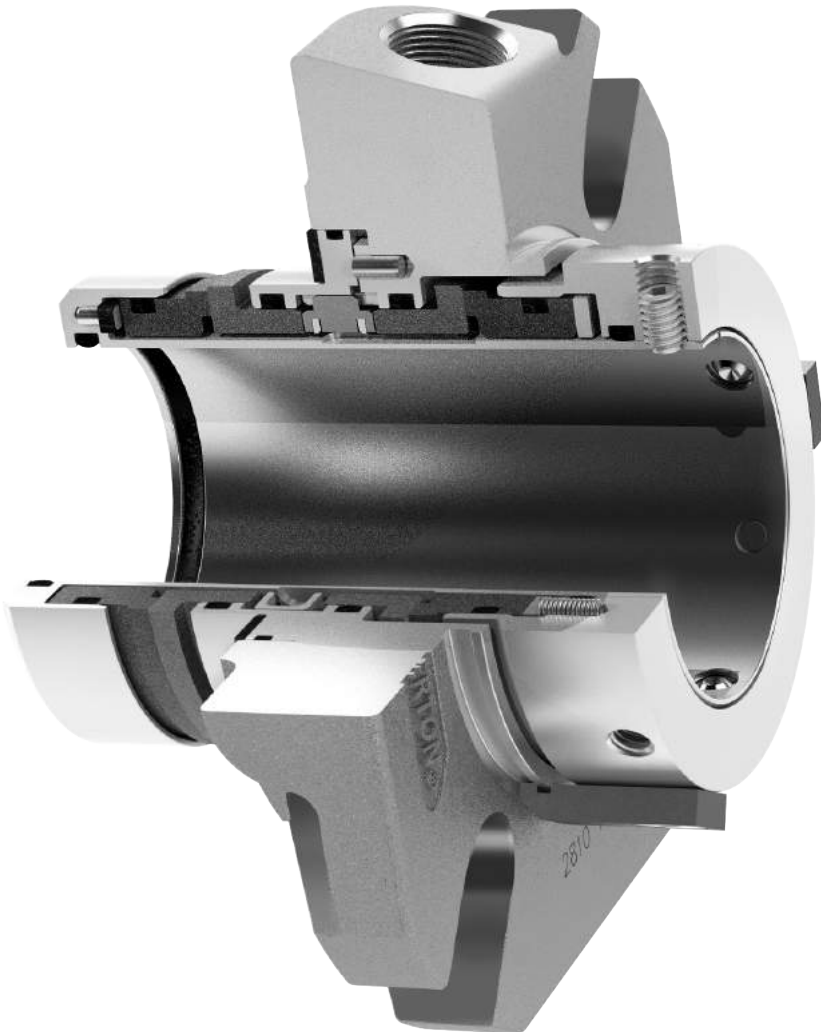

# 2810 Heavy-Duty Modular Double Cartridge Seal

## Installation, Operation and Rebuild Instructions



### TABLE OF CONTENTS

|       |  |         |
|-------|--|---------|
| 1.0   | Cautions .....   | 2       |
| 2.0   | Transport and Storage .....  | 2       |
| 3.0   | Description .....  | 2 – 6   |
| 3.1   | Parts Identification .....   | 2       |
| 3.2   | Operating Parameters .....   | 3       |
| 3.3   | Intended Use .....   | 3       |
| 3.4   | Dimensional Data .....   | 4 – 5   |
| 4.0   | Preparation for Installation .....                                     | 6       |
| 4.1   | Equipment .....  | 6       |
| 4.2   | Mechanical Seal .....  | 7       |
| 5.0   | Seal Installation .....  | 8       |
| 6.0   | Commissioning/Equipment Start-up .....                                 | 9       |
| 7.0   | Decommissioning/Equipment Shut Down .....                              | 10      |
| 8.0   | Spare Parts .....  | 10      |
| 9.0   | Seal Rebuild .....   | 11      |
| 9.1   | Seal Rebuild .....   | 11      |
| 9.1.1 | Seal Disassembly .....   | 11 – 12 |
| 9.1.2 | Seal Assembly .....  | 13 – 16 |
| 10.0  | Mechanical Seal Returns and Hazard<br>Communication Requirements ..... | 16      |

#### Seal Data Reference

(from Box Label)

ITEM # \_\_\_\_\_

SEAL \_\_\_\_\_

(Example: 2810 1.875 SA CB/SSC S FKM)

INSTALLATION DATE \_\_\_\_\_

## 1.0 CAUTIONS

These instructions are general in nature. It is assumed that the installer is familiar with seals and certainly with the requirements of their plant for the successful use of mechanical seals. If in doubt, seek assistance from someone in the plant who is familiar with seals or delay the installation until a seal representative is available. All necessary auxiliary arrangements for successful operation (heating, cooling, flushing) as well as safety devices must be employed. These decisions are to be made by the user. The decision to use this seal or any other Chesterton seal in a particular service is the customer's responsibility.

Do not touch the mechanical seal for any reason while it is operating. Lockout or uncouple the driver prior to personal contact with the seal. Do not touch the mechanical seal while it is in contact with hot or cold fluids. Ensure that all the mechanical seal materials are compatible with the process fluid. This will prevent possible personal injury.

## 2.0 TRANSPORT AND STORAGE

Transport and store seals in their original packaging. Mechanical seals contain components that may be subject to alteration and aging. It is therefore important to observe the following conditions for storage:

- Dust free environment
- Moderately ventilated at room temperature
- Avoid exposure to direct sunlight and heat
- For elastomers, storage conditions according to ISO 2230 should be observed.

## 3.0 DESCRIPTION

### 3.1 Parts Identification

Figure 1

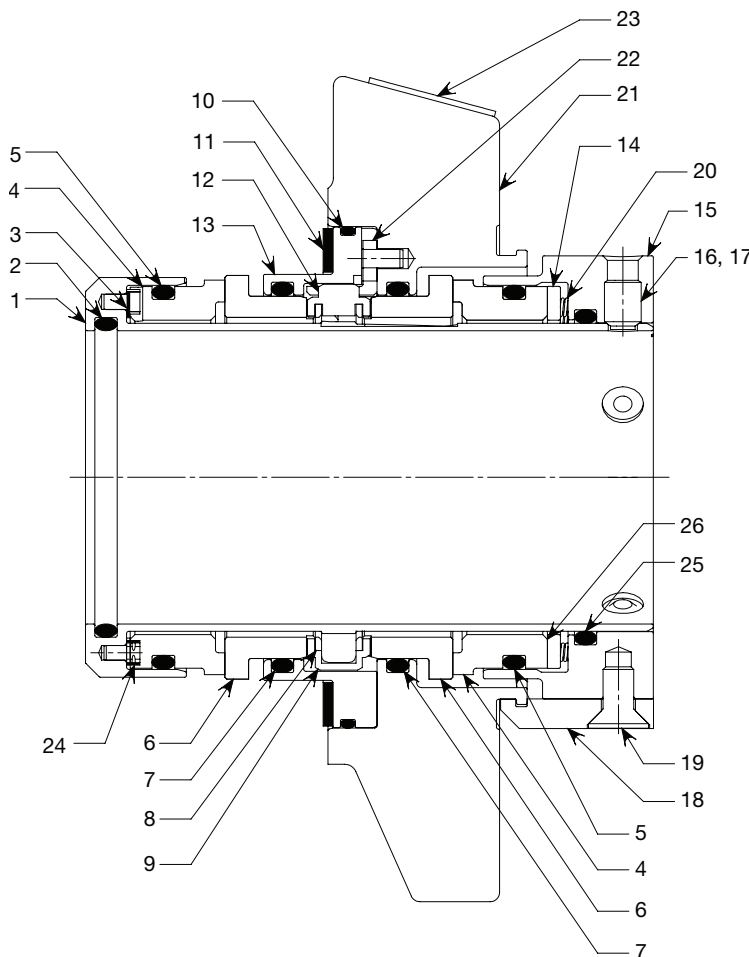

#### KEY

- 1 – Sleeve Assembly
- 2 – Shaft O-Ring (V)
- 3 – Rotary Cushion
- 4 – Rotary Seal Ring
- 5 – Rotary O-Ring (W)
- 6 – Stationary Seal Ring
- 7 – Stationary O-Ring (X)
- 8 – Drive Channel
- 9 – Channel Clip
- 10 – Adapter O-Ring (Z)
- 11 – Gasket
- 12 – Flow Deflector
- 13 – Adapter
- 14 – Follower Assembly
- 15 – Lock Ring
- 16 – Cup Point Set Screw (not shown)
- 17 – 1/4 Dog Set Screw
- 18 – Centering Clip
- 19 – Flat Head Screw
- 20 – Spring
- 21 – Gland
- 22 – Drive Assembly
- 23 – Cap Plug
- 24 – Drive Tube
- 25 – Lock Ring O-Ring (Y)
- 26 – Drive Tube (not shown)

### 3.0 DESCRIPTION cont.

---

#### 3.2 Operating Parameters\*

**Pressure Limits:**

2810 Seals can withstand operating pressures from vacuum (710 mm or 28" Hg) to the maximum pressures.

**Process Pressure:**

25 mm – 120 mm (1.000" – 4.750") up to 40 barg (600 psig)

**Barrier Pressure:**

25 mm – 65 mm (1.000" – 2.625") up to 17 barg (250 psig)

70 mm – 120 mm (2.750" – 4.750") up to 14 barg (200 psig)

**Maintain process pressure at no more than 4 barg (50psig) below barrier pressure**

**2 barg (30psig) minimum barrier pressure**

**Standard Materials:**

**All Metal Parts:**

316 Stainless Steel/EN 1.4401

**Springs:** Alloy C-276/EN 2.4819

**Rotary Face:** CB; SSC; TC

**Stationary Face:** SSC; TC

**Elastomers\*\*:** FKM, EPDM, FEPM, or FFKM

**\*\*Other materials available upon request.**

**Speed Limits:**

25 mm – 120 mm (1.000" – 4.750") up to 25 mps (5000 FPM)

**Temperature Limits:**

Elastomers

To 150°C (300°F) EPDM

To 205°C (400°F) FEPM, FKM

To 260°C (500°F) FFKM

**\*Environmental controls are required for the specific application.**

**Limits can change depending on operating conditions, size and seal ring material.**

**Consult Chesterton Mechanical Seal Application Engineering for operating conditions outside of these published parameters.**

#### 3.3 Intended Use

The mechanical seal is to be operated within the operating parameters as specified. For use beyond the intended application and/or outside the operating parameters, consult Chesterton Mechanical Seal Application Engineering to confirm the suitability of the mechanical seal prior to putting the mechanical seal in operation.

### 3.0 DESCRIPTION cont.

#### 3.4 Dimensional Data (Drawings)

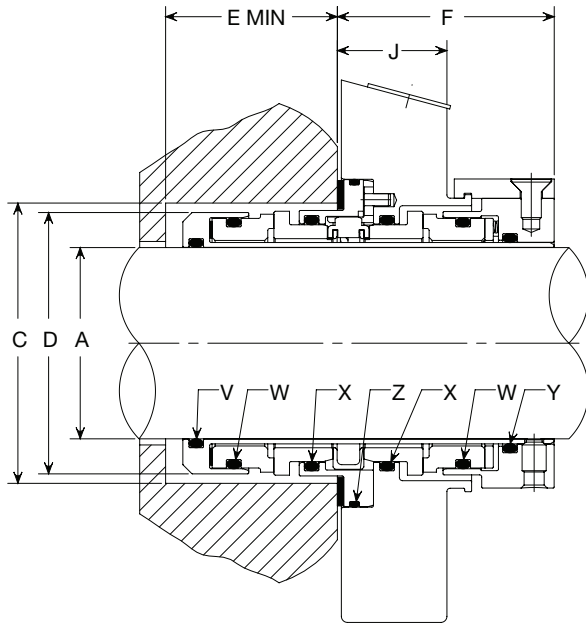
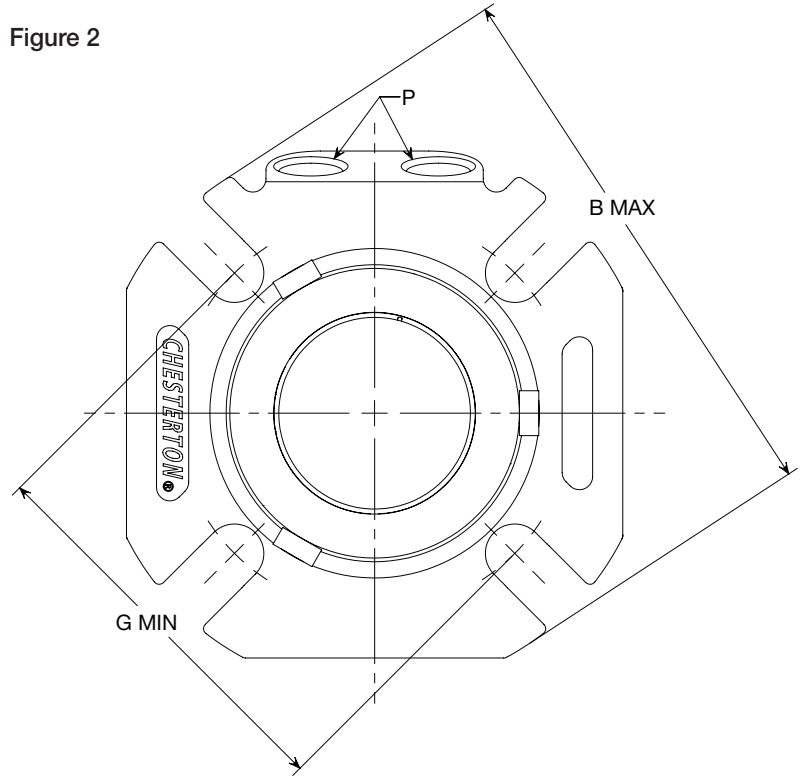

Figure 2



#### 3.4.1 Dimensional Data

METRIC - Millimeters

| SHAFT SIZE | GLAND OD | STUFFING BOX BORE |       | IB SEAL DIA | SB DEPTH | OB LENGTH | BOLT CIRCLE BY BOLT SIZE |       |       |       | STUFFING BOX TO BOLT SURFACE | NPT SIZE |
|------------|----------|-------------------|-------|-------------|----------|-----------|--------------------------|-------|-------|-------|------------------------------|----------|
|            |          | A                 | B MAX |             |          |           | C MIN                    | C MAX | D MAX | E MIN |                              |          |
|            |          |                   |       |             |          |           | 10 mm                    | 12 mm | 16 mm | 20 mm |                              |          |
| 25         | 104      | 44.5              | 51.1  | 42.9        | 40       | 53.8      | 73.2                     | -     | -     | -     | 28.7                         | 1/4 - 18 |
| 28         | 104      | 47.8              | 51.8  | 46.2        | 40       | 53.8      | 73.2                     | -     | -     | -     | 28.7                         | 1/4 - 18 |
| 30         | 104      | 51.0              | 56.6  | 49.5        | 40       | 53.8      | 78.0                     | -     | -     | -     | 28.7                         | 1/4 - 18 |
| 30 OS      | 127      | 59.4              | 68.1  | 49.5        | 40       | 53.8      | 90.0                     | -     | -     | -     | 28.7                         | 1/4 - 18 |
| 32         | 104      | 49.0              | 58.7  | 47.4        | 40       | 53.8      | 80.1                     | -     | -     | -     | 28.7                         | 1/4 - 18 |
| 33         | 111      | 49.0              | 58.7  | 47.4        | 40       | 53.8      | 80.1                     | 81.6  | -     | -     | 28.7                         | 1/4 - 18 |
| 35         | 111      | 53.9              | 59.2  | 52.4        | 40       | 53.8      | 83.2                     | 85.2  | -     | -     | 28.7                         | 1/4 - 18 |
| 38         | 114      | 57.1              | 62.0  | 55.5        | 40       | 53.8      | 85.8                     | 88.6  | -     | -     | 28.7                         | 3/8 - 18 |
| 40         | 127      | 59.0              | 68.3  | 57.5        | 40       | 53.8      | 90.0                     | 92.0  | -     | -     | 28.7                         | 3/8 - 18 |
| 40 OS      | 127      | 69.3              | 74.3  | 57.5        | 40       | 53.8      | 96.5                     | -     | -     | -     | 28.7                         | 3/8 - 18 |
| 42         | 127      | 61.0              | 68.3  | 59.5        | 40       | 53.8      | 90.2                     | 92.0  | -     | -     | 28.7                         | 3/8 - 18 |
| 43         | 127      | 62.0              | 68.8  | 60.5        | 40       | 53.8      | 94.0                     | 96.0  | -     | -     | 28.7                         | 3/8 - 18 |
| 45         | 139      | 64.0              | 73.4  | 62.5        | 40       | 53.8      | 94.8                     | 96.8  | -     | -     | 28.7                         | 3/8 - 18 |
| 48         | 139      | 67.0              | 73.8  | 65.5        | 40       | 53.8      | 95.3                     | 97.3  | -     | -     | 28.7                         | 3/8 - 18 |
| 50         | 139      | 69.0              | 78.5  | 67.5        | 40       | 53.8      | 100.0                    | 102.0 | -     | -     | 28.7                         | 3/8 - 18 |
| 50 OS      | 152      | 85.2              | 94.1  | 67.5        | 40       | 53.8      | 118.6                    | 120.6 | -     | -     | 28.7                         | 3/8 - 18 |
| 53         | 152      | 73.0              | 87.4  | 71.4        | 40       | 53.8      | 108.3                    | 110.3 | 114.3 | -     | 28.7                         | 3/8 - 18 |
| 55         | 152      | 74.0              | 81.2  | 72.4        | 40       | 53.8      | 104.5                    | 106.5 | 110.5 | -     | 28.7                         | 3/8 - 18 |
| 58         | 152      | 79.3              | 91.9  | 77.8        | 40       | 53.8      | 116.2                    | 118.2 | 122.2 | -     | 28.7                         | 3/8 - 18 |
| 60         | 152      | 79.3              | 91.9  | 77.8        | 40       | 53.8      | 116.2                    | 118.2 | 122.2 | -     | 28.7                         | 3/8 - 18 |
| 60 OS      | 165      | 78.9              | 107.5 | 77.8        | 40       | 53.8      | 129.8                    | 131.8 | -     | -     | 28.7                         | 3/8 - 18 |
| 65         | 164      | 85.7              | 100.1 | 84.1        | 40       | 53.8      | 127.4                    | 129.4 | 133.4 | -     | 28.7                         | 3/8 - 18 |
| 70         | 196      | 95.0              | 113.0 | 93.0        | 52       | 64.0      | -                        | 137.0 | 141.0 | -     | 34.0                         | 1/2 - 14 |
| 75         | 202      | 101.0             | 119.0 | 99.0        | 52       | 64.0      | -                        | 143.0 | 147.0 | -     | 34.0                         | 1/2 - 14 |
| 80         | 203      | 106.0             | 122.0 | 103.0       | 52       | 64.0      | -                        | 150.0 | 154.0 | -     | 34.0                         | 1/2 - 14 |
| 85         | 211      | 111.0             | 129.0 | 109.0       | 52       | 64.0      | -                        | 156.5 | 160.5 | 164.0 | 34.0                         | 1/2 - 14 |
| 90         | 215      | 116.0             | 132.0 | 114.0       | 52       | 64.0      | -                        | 160.0 | 164.0 | 168.0 | 34.0                         | 1/2 - 14 |
| 95         | 222      | 121.0             | 138.0 | 118.0       | 52       | 64.0      | -                        | 161.0 | 165.0 | 170.0 | 34.0                         | 1/2 - 14 |
| 100        | 228      | 127.0             | 144.0 | 125.0       | 52       | 64.0      | -                        | 168.0 | 172.0 | 177.0 | 34.0                         | 1/2 - 14 |
| 110        | 237      | 137.0             | 154.0 | 134.0       | 52       | 64.0      | -                        | 178.0 | 182.0 | 186.0 | 34.0                         | 1/2 - 14 |
| 120        | 267      | 146.0             | 163.0 | 144.0       | 52       | 64.0      | -                        | 191.0 | 195.0 | 198.5 | 34.0                         | 1/2 - 14 |

### 3.0 DESCRIPTION cont.

#### 3.4.2 Dimensional Data

INCH

| SHAFT SIZE | GLAND OD | STUFFING BOX BORE |       | IB SEAL DIA | SB DEPTH | OB LENGTH | BOLT CIRCLE BY BOLT SIZE |      |      |      | STUFFING BOX TO BOLT SURFACE | NPT SIZE |
|------------|----------|-------------------|-------|-------------|----------|-----------|--------------------------|------|------|------|------------------------------|----------|
|            |          |                   |       |             |          |           | G MIN                    |      |      |      |                              |          |
|            |          |                   |       |             |          |           | 3/8"                     | 1/2" | 5/8" | 3/4" |                              |          |
| A          | B MAX    | C MIN             | C MAX | D MAX       | E MIN    | F MAX     |                          |      |      |      | J MAX                        | P        |
| 1.000      | 4.11     | 1.75              | 2.01  | 1.69        | 1.58     | 2.12      | 2.88                     | -    | -    | -    | 1.13                         | 1/4 - 18 |
| 1.125      | 4.11     | 1.88              | 2.04  | 1.82        | 1.58     | 2.12      | 2.88                     | -    | -    | -    | 1.13                         | 1/4 - 18 |
| 1.125 OS   | 4.49     | 2.61              | 2.92  | 1.82        | 1.58     | 2.12      | 3.77                     | -    | -    | -    | 1.13                         | 1/4 - 18 |
| 1.250      | 4.11     | 2.00              | 2.27  | 1.94        | 1.58     | 2.12      | 3.14                     | -    | -    | -    | 1.13                         | 1/4 - 18 |
| 1.375      | 4.45     | 2.13              | 2.33  | 2.06        | 1.58     | 2.12      | 3.27                     | 3.40 | -    | -    | 1.13                         | 1/4 - 18 |
| 1.375 OS   | 5.39     | 2.73              | 2.92  | 2.06        | 1.58     | 2.12      | 3.78                     | -    | -    | -    | 1.13                         | 1/4 - 18 |
| 1.500      | 4.50     | 2.25              | 2.44  | 2.19        | 1.58     | 2.12      | 3.40                     | 3.53 | -    | -    | 1.13                         | 1/4 - 18 |
| 1.625      | 5.00     | 2.38              | 2.69  | 2.31        | 1.58     | 2.12      | 3.52                     | 3.64 | -    | -    | 1.13                         | 3/8 - 18 |
| 1.750      | 5.50     | 2.50              | 2.81  | 2.44        | 1.58     | 2.12      | 3.62                     | 3.75 | -    | -    | 1.13                         | 3/8 - 18 |
| 1.750 OS   | 6.65     | 3.48              | 3.73  | 2.44        | 1.58     | 2.12      | 4.59                     | 4.72 | -    | -    | 1.13                         | 3/8 - 18 |
| 1.875      | 5.50     | 2.63              | 2.94  | 2.56        | 1.58     | 2.12      | 3.75                     | 3.88 | -    | -    | 1.13                         | 3/8 - 18 |
| 1.875 OS   | 5.99     | 3.53              | 3.79  | 2.56        | 1.58     | 2.12      | 4.65                     | 4.78 | -    | -    | 1.13                         | 3/8 - 18 |
| 2.000      | 5.50     | 2.75              | 3.19  | 2.69        | 1.58     | 2.12      | 4.13                     | 4.27 | -    | -    | 1.13                         | 3/8 - 18 |
| 2.125      | 6.00     | 2.88              | 3.44  | 2.81        | 1.58     | 2.12      | 4.25                     | 4.38 | 4.50 | -    | 1.13                         | 3/8 - 18 |
| 2.125 OS   | 6.99     | 3.86              | 4.23  | 2.81        | 1.58     | 2.12      | 5.09                     | 5.22 | 5.34 | -    | 1.13                         | 3/8 - 18 |
| 2.250      | 6.00     | 3.00              | 3.47  | 2.94        | 1.58     | 2.12      | 4.37                     | 4.50 | 4.62 | -    | 1.13                         | 3/8 - 18 |
| 2.375      | 6.00     | 3.13              | 3.62  | 3.06        | 1.58     | 2.12      | 4.56                     | 4.75 | 4.82 | -    | 1.13                         | 3/8 - 18 |
| 2.375 OS   | 8.39     | 4.11              | 4.48  | 3.06        | 1.58     | 2.12      | 5.34                     | 5.47 | 5.59 | -    | 1.13                         | 3/8 - 18 |
| 2.500      | 6.50     | 3.25              | 3.81  | 3.19        | 1.58     | 2.12      | 4.62                     | 4.75 | 4.87 | -    | 1.13                         | 3/8 - 18 |
| 2.500 OS   | 7.76     | 4.48              | 5.23  | 3.19        | 1.58     | 2.12      | 6.09                     | 6.22 | 6.34 | -    | 1.13                         | 3/8 - 18 |
| 2.625      | 6.50     | 3.38              | 3.94  | 3.31        | 1.58     | 2.12      | 5.00                     | 5.13 | 5.26 | -    | 1.13                         | 3/8 - 18 |
| 2.625 OS   | 6.98     | 4.55              | 4.76  | 3.31        | 1.58     | 2.12      | 5.62                     | 5.75 | 5.87 | -    | 1.13                         | 3/8 - 18 |
| 2.750      | 7.71     | 3.76              | 4.44  | 3.67        | 2.05     | 2.50      | -                        | 5.42 | 5.55 | -    | 1.35                         | 1/2 - 14 |
| 2.750 OS   | 7.89     | 4.45              | 4.76  | 3.67        | 2.05     | 2.50      | -                        | 5.84 | 5.97 | 6.09 | 1.35                         | 1/2 - 14 |
| 2.875      | 7.83     | 3.88              | 4.56  | 3.79        | 2.05     | 2.50      | -                        | 5.50 | 5.72 | -    | 1.35                         | 1/2 - 14 |
| 3.000      | 7.94     | 4.00              | 4.69  | 3.91        | 2.05     | 2.50      | -                        | 5.65 | 5.77 | -    | 1.35                         | 1/2 - 14 |
| 3.000 OS   | 8.64     | 4.92              | 5.37  | 3.91        | 2.05     | 2.50      | -                        | 6.45 | 6.58 | 6.70 | 1.35                         | 1/2 - 14 |
| 3.125      | 7.99     | 4.13              | 4.81  | 4.04        | 2.05     | 2.50      | -                        | 5.80 | 5.92 | -    | 1.35                         | 1/2 - 14 |
| 3.250      | 8.19     | 4.25              | 4.94  | 4.16        | 2.05     | 2.50      | -                        | 5.93 | 6.17 | -    | 1.35                         | 1/2 - 14 |
| 3.375      | 8.31     | 4.38              | 5.06  | 4.29        | 2.05     | 2.50      | -                        | 6.05 | 6.30 | 6.39 | 1.35                         | 1/2 - 14 |
| 3.375 OS   | 8.39     | 4.95              | 5.26  | 4.29        | 2.05     | 2.50      | -                        | 6.33 | 6.45 | 6.58 | 1.35                         | 1/2 - 14 |
| 3.500      | 8.44     | 4.50              | 5.19  | 4.41        | 2.05     | 2.50      | -                        | 6.18 | 6.31 | 6.43 | 1.35                         | 1/2 - 14 |
| 3.625      | 8.49     | 4.63              | 5.31  | 4.54        | 2.05     | 2.50      | -                        | 6.31 | 6.55 | 6.62 | 1.35                         | 1/2 - 14 |
| 3.750      | 8.72     | 4.75              | 5.44  | 4.66        | 2.05     | 2.50      | -                        | 6.38 | 6.51 | 6.63 | 1.35                         | 1/2 - 14 |
| 3.750 OS   | 9.76     | 5.95              | 6.38  | 4.66        | 2.05     | 2.50      | -                        | 7.46 | 7.59 | -    | 1.35                         | 1/2 - 14 |
| 3.875      | 8.84     | 4.88              | 5.56  | 4.79        | 2.05     | 2.50      | -                        | 6.52 | 6.75 | 6.82 | 1.35                         | 1/2 - 14 |
| 4.000      | 8.96     | 5.00              | 5.69  | 4.91        | 2.05     | 2.50      | -                        | 6.66 | 6.78 | 6.91 | 1.35                         | 1/2 - 14 |
| 4.125      | 8.99     | 5.13              | 5.81  | 5.04        | 2.05     | 2.50      | -                        | 6.79 | 6.90 | 7.03 | 1.35                         | 1/2 - 14 |
| 4.125 OS   | 9.76     | 5.95              | 6.26  | 5.04        | 2.05     | 2.50      | -                        | 7.33 | 7.45 | 7.58 | 1.35                         | 1/2 - 14 |
| 4.250      | 8.99     | 5.25              | 5.94  | 5.16        | 2.05     | 2.50      | -                        | 6.92 | 7.17 | 7.26 | 1.35                         | 1/2 - 14 |
| 4.375      | 9.34     | 5.38              | 6.06  | 5.29        | 2.05     | 2.50      | -                        | 7.03 | 7.15 | 7.28 | 1.35                         | 1/2 - 14 |
| 4.500      | 9.49     | 5.50              | 6.19  | 5.41        | 2.05     | 2.50      | -                        | 7.18 | 7.30 | 7.43 | 1.35                         | 1/2 - 14 |
| 4.500 OS   | 12.49    | 6.73              | 7.49  | 5.41        | 2.05     | 2.50      | -                        | 8.56 | 8.68 | 8.81 | 1.35                         | 1/2 - 14 |
| 4.625      | 9.49     | 5.63              | 6.31  | 5.54        | 2.05     | 2.50      | -                        | 7.32 | 7.56 | 7.65 | 1.35                         | 1/2 - 14 |
| 4.750      | 10.49    | 5.75              | 6.44  | 5.66        | 2.05     | 2.50      | -                        | 7.41 | 7.66 | 7.75 | 1.35                         | 1/2 - 14 |
| 4.750 OS   | 11.39    | 7.20              | 7.63  | 5.66        | 2.05     | 2.50      | -                        | 8.21 | 8.84 | 8.96 | 1.35                         | 1/2 - 14 |

## 4.0 PREPARATION FOR INSTALLATION

### 4.1 Equipment

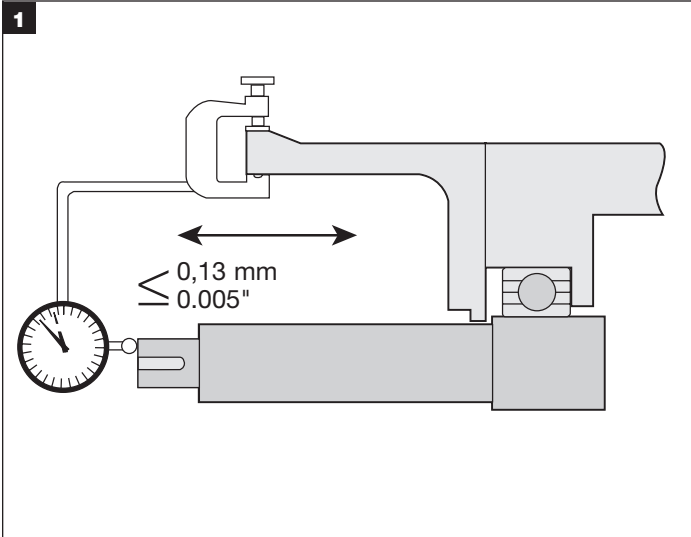

If practical, place the dial indicator tip on the end of the shaft sleeve or on a step in the shaft to measure end play. Alternately push and pull the shaft in the axial direction. If the bearings are in good condition, end play should not exceed 0,13 mm (.005").

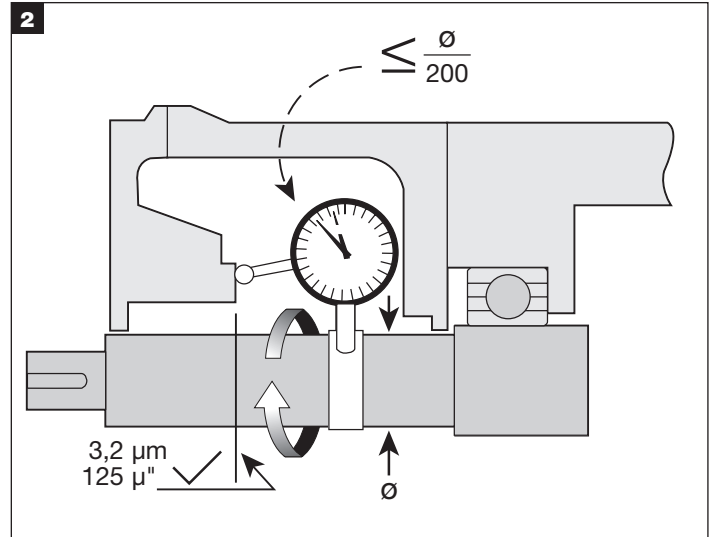

If possible, attach a base dial indicator to the shaft and rotate both the indicator and shaft slowly while reading the runout of the stuffing box face. Misalignment of the stuffing box face relative to the shaft should not exceed 0,005 mm TIR per mm (.005 in per inch) of shaft diameter.

The stuffing box face must be flat and smooth enough to seal the gland. Surface roughness should be 3,2 microns (125 microinch) Ra maximum for gaskets and 1,1 micron (45 microinch) Ra for O-Rings. Steps between halves of split case pumps should be machined flat. Make sure the stuffing box is clean and clear along its entire length.

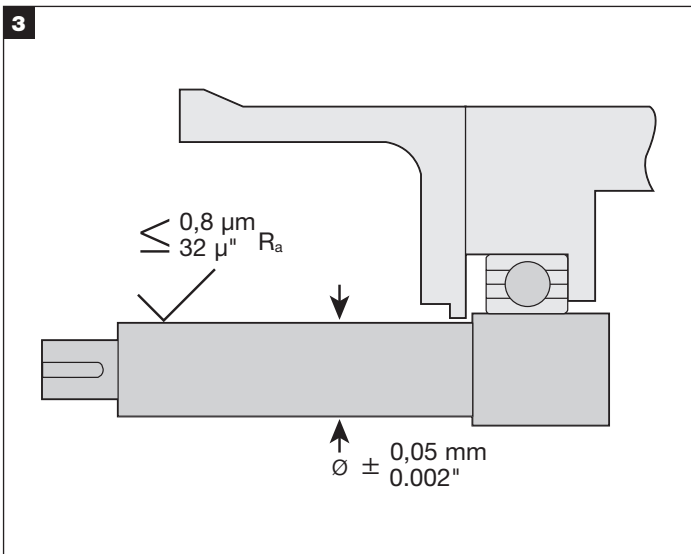

Remove all sharp corners, burrs, and scratches on the shaft, especially in areas where the O-Ring will slide, and polish if necessary to achieve a 1,1 micron (45 microinch) Ra finish. Make sure the shaft or sleeve diameter is within 0,05 mm (.002") of nominal.

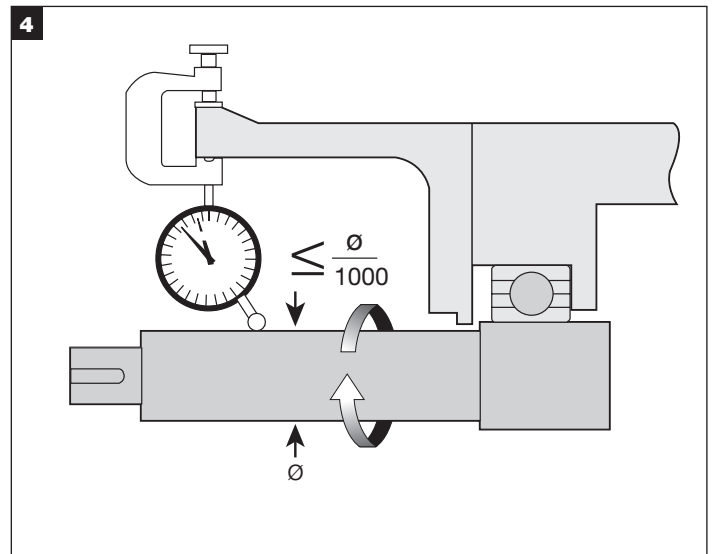

Use a dial indicator to measure the shaft runout in the area where the seal will be installed. Runout should not exceed 0,001 mm TIR per mm (.001 in per inch) of shaft diameter.

### 4.2 Mechanical Seal

1. Check to ensure that the O-Rings installed in this seal are compatible with the fluid being sealed.
2. The 1/4 dog set screws go into the smaller holes in the sleeve. The dimples on the outside diameter of the lock ring indicate the position of the 1/4 dog set screws. Do not disengage these screws from the sleeve when positioning the seal. The cup point set screws go through the larger holes in the sleeve. Make sure all screws are engaged in the sleeve but do not protrude into the inside diameter bore. Also, when repositioning or removing the seal, make sure the centering clips and flat head screws are engaged.
3. Centering clips have been preset at the factory. If for any reason you loosen or remove the centering clip flat head screws, retighten as follows prior to installing the seal on the equipment: Tighten the flat head screw finger tight, ensuring the centering clips are properly engaged. Then using a hex key, tighten flat head screw an additional 1/8 turn. This will approximate the 4,5 Nm (40 inch-pounds) of torque for sizes 25 mm – 65 mm (1.000" – 2.650"), 7,8 Nm (70 inch-pounds) of torque for 70 mm – 120 mm (2.750" – 4.750") set at the factory.

## 5.0 SEAL INSTALLATION



Tools required for installation: Hex key and grease (**supplied with seal**). Open end or socket/torque wrench (size dependent on mounting bolt size; **supplied by customer**). **IMPORTANT: As manufactured seal data can be accessed from the installed RFID tag; you may also choose to fill in seal data reference from the box label on the cover page of these instructions. Remove plastic from fluid ports (not shown).**

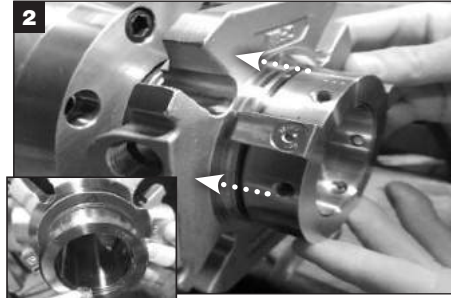

Apply a thin film of grease to the shaft/O-Ring (V) and slide seal onto the shaft by pushing on the gland. **CAUTION: Ensure that all set screws are engaged through the sleeve but do not protrude into the sleeve inside diameter bore.**



Reassemble the pump and make necessary shaft alignments and impeller adjustments. The impeller can be reset at any time, as long as the centering clips are in place and the seal set screws are loosened while the shaft is being moved. (see Figure 4) for port orientation. **CAUTION: See (4.2.3 Preparation for Installation – Mechanical Seal step 3.)**

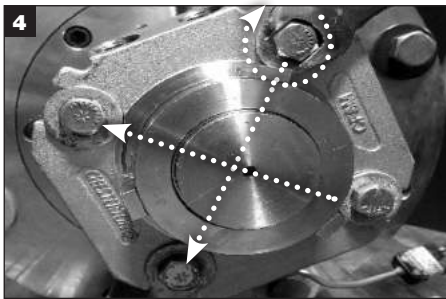

Tighten the gland bolts evenly. **IMPORTANT: The gland bolts must be tightened before tightening the set screws onto the shaft. Gland bolt torque is dependent on application. IMPORTANT: Piping connections should not be made prior to tightening the gland bolts.**

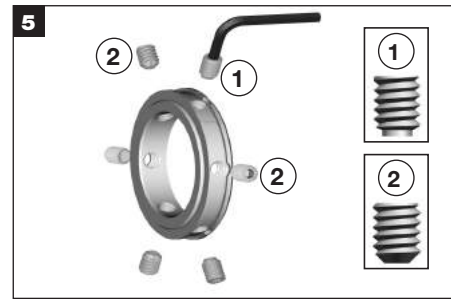

**IMPORTANT: 1/4 dog set screws (1) must be tightened FIRST and cup point set screws (2) must be tightened last.** 1/4 dog set screw locations are marked with a dimple on the outside diameter of the lock ring, next to the screw holes.

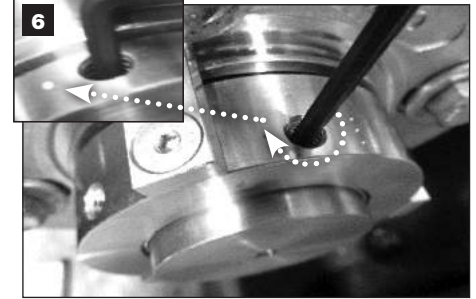

Tighten three 1/4 dog set screws (1) (see inset image, marked with a dimple) evenly with the hex key provided.

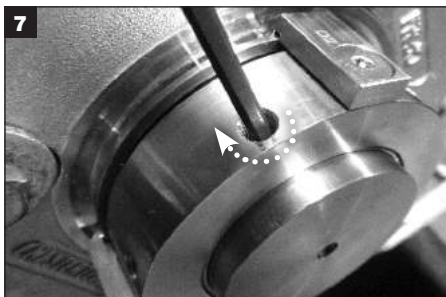

Tighten cup point set screws (2) evenly with the hex key provided. **IMPORTANT: After all sets screws have been tightened by hand, retighten with a torque wrench:**  
**Sizes 25 mm – 65 mm (1.000" – 2.625")**  
 to 5,5 – 6,5 Nm (50 – 60 in-lbs.)  
**Sizes 70 mm – 120 mm (2.750" – 4.750")**  
 to 12 – 13 Nm (105 – 115 in-lbs.)

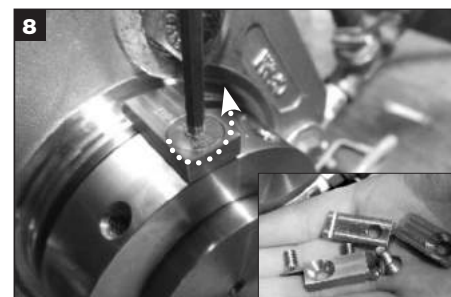

Remove all flat head screws and centering clips and retain for future use when making impeller adjustments and/or seal removal.



**IMPORTANT: To ensure that the gland is properly centered over the sleeve turn the shaft by hand and make sure the seal turns freely. If you hear/feel metal to metal contact within the seal, it was improperly centered. Re-install the centering clips finger tight. Remove any piping connections. Loosen the gland bolts. Fully tighten clips. Loosen the set screws. Re-tighten the gland bolts. Re-tighten the set screws. Remove the clips. If metal to metal contact still exists check the centering of the stuffing box.**



6.1 Attach appropriate environmental controls to the seal. (see Figure 3)

6.2 Take all necessary precautions and follow normal safety procedures before starting the equipment

\* Please contact Chesterton Mechanical Seal Application Engineering for assistance regarding cartridge seals.

Figure 3

**Barrier/Buffer Fluid**

**COUNTER-CLOCKWISE**  
shaft rotation

The cool fluid from the bottom of the convection tank enters through the left port.

**CLOCKWISE**  
shaft rotation

The cool fluid from the bottom of the convection tank enters through the right port.

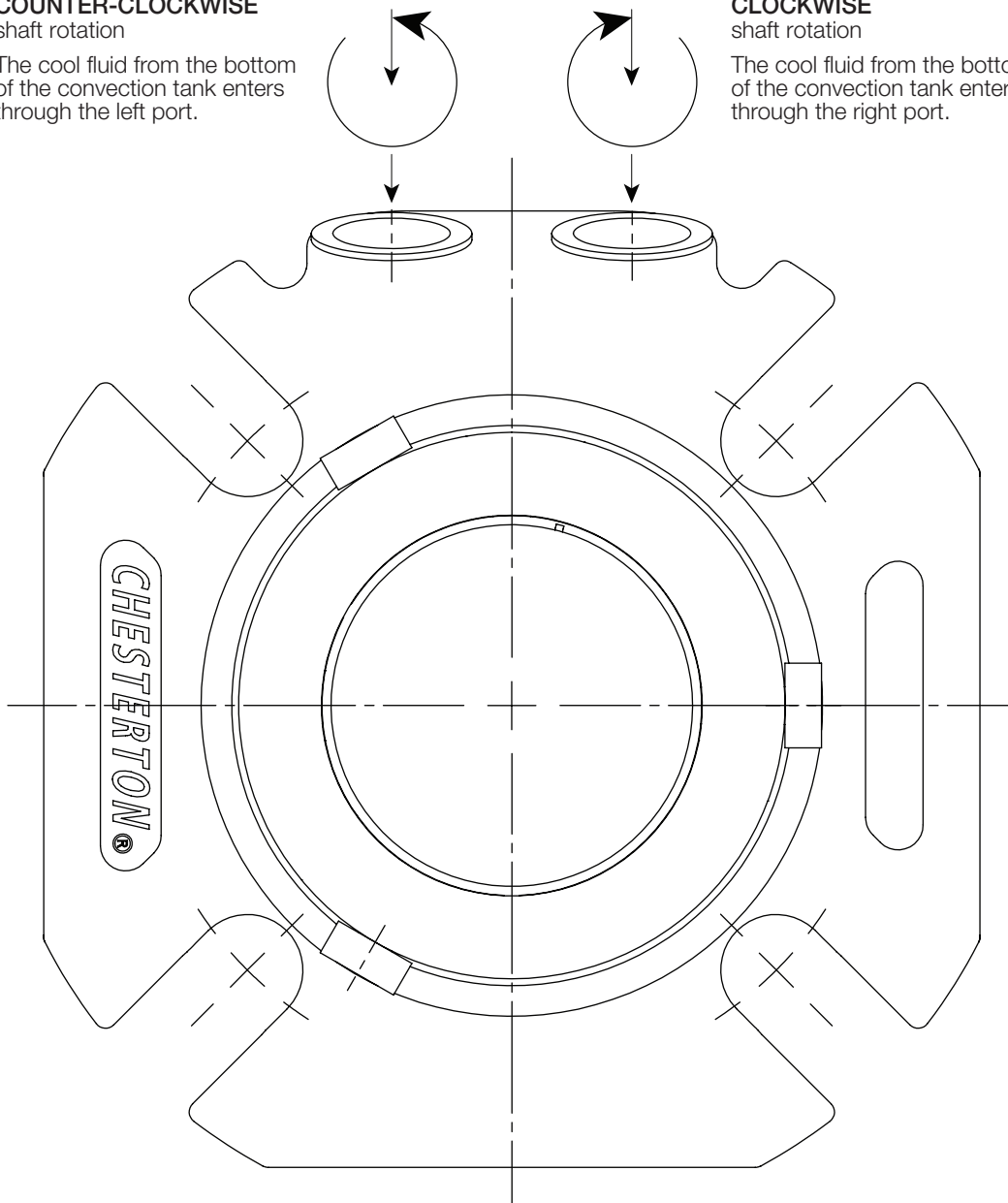

## 7.0 DECOMMISSIONING / EQUIPMENT SHUT DOWN

---

Ensure that the equipment is electrically isolated. If the equipment has been used on toxic or hazardous fluids, ensure that the equipment is correctly decontaminated and made safe prior to commencing work. Ensure that the pump is isolated and check that the stuffing box is drained from any fluid and

pressure is fully released. **IMPORTANT: Replace centering clips prior to seal removal from equipment!** Remove the seal from equipment in the reverse order from installation instructions. In case of disposal, ensure the local regulations and requirements for disposal or recycling of the different components in the seal are adhered to.

## 8.0 SPARE PARTS

---

Use only Chesterton original spare parts. Use of non-original spare parts represents risk of failure, danger to persons/ equipment and voids the product warranty.

Spare Parts Kit can be purchased from Chesterton, referencing the (as manufactured) seal data from the installed RFID tag or from recorded data on the cover page of these instructions.

## 9.0 SEAL REBUILD

---

### 9.1 Seal Rebuild

A correctly installed and operated mechanical seal requires little maintenance. It is recommended to periodically check the seal for leakage. Some components of a mechanical seal such as seal rings, O-Rings, etc., require replacement over time. While a seal is installed and operating, maintenance is not possible. Therefore it is recommended that a spare seal unit or a spare parts kit be held in stock to allow quick repair.

1. Note the condition of the parts, including elastomer surfaces and gland springs. Analyze the cause of failure and correct the problem, if possible, before reinstalling the seal.
2. Clean all elastomer and gasket surfaces with an approved cleaning solvent that complies with local and site regulations.

## 9.0 SEAL REBUILD

### 9.1.1 Seal Disassembly

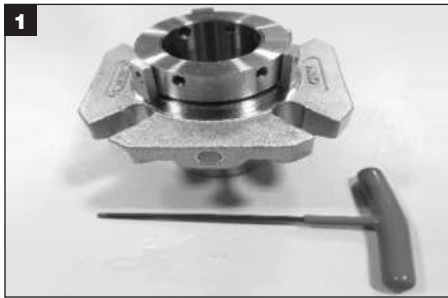

Tools required for disassembly of seal: Hex key (supplied with seal); tweezers and a curved pick (supplied by customer; for removal of O-Rings and drive tube).

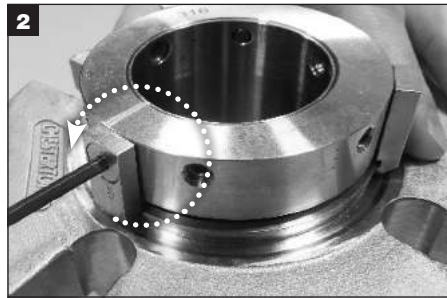

Remove the centering clips and discard.

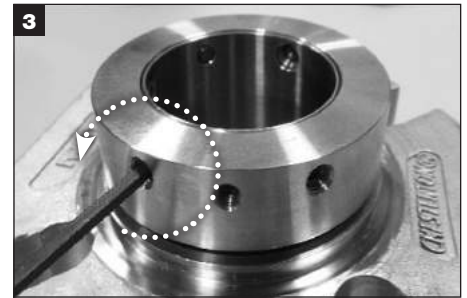

Remove all cup point and 1/4 dog set screws from the lock ring and discard.

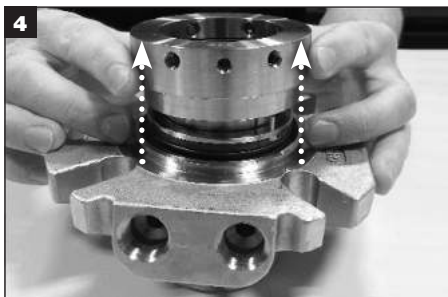

Remove the lock ring from sleeve and set aside.

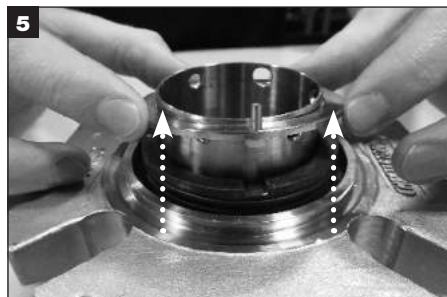

Remove the follower assembly. Remove the drive tube and discard. Set aside follower assembly.



Remove outboard rotary seal ring and discard.

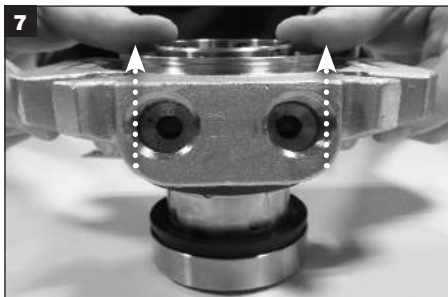

Separate gland assembly from sleeve assembly and set aside.



Remove the inboard stationary seal ring from the sleeve and discard.



Remove the inboard rotary seal ring from the sleeve and discard.

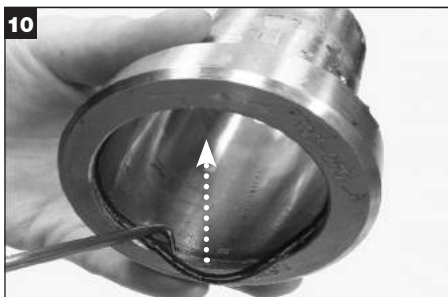

Remove the shaft O-Ring (V) from sleeve and discard.



Remove the drive tube from the sleeve drive lugs and discard.



Remove all springs from the lock ring and discard.

## 9.0 SEAL REBUILD cont.

### 9.1.1 Seal Disassembly cont.



Remove the lock ring O-Ring (Y) and discard.



Remove the outboard stationary seal ring from gland and discard.

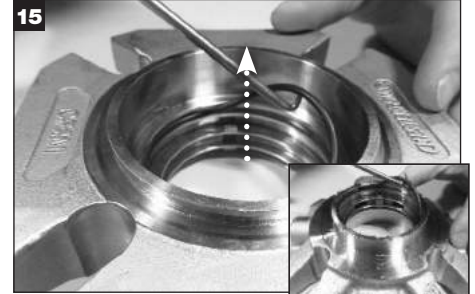

Remove the O-Ring (X) from the gland inside diameter and discard.



Remove the gasket from the adapter and discard.



Remove the inboard stationary seal ring from gland and discard.

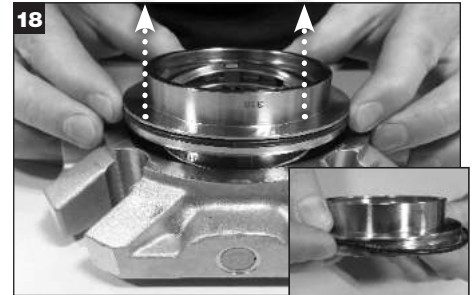

Remove the adapter from the gland. Remove the adapter O-Ring (Z) and discard. Set the adapter aside.



Remove the drive channel from gland; remove the channel clips and the flow deflector from the channel and discard.

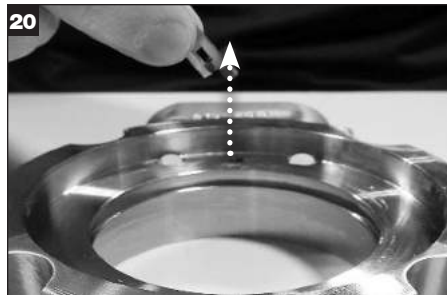

Remove the drive assembly from the gland and discard.

## 9.0 SEAL REBUILD cont.

### 9.1.2 Seal Assembly



Tools required for assembly of seal: Hex key and two types of grease (supplied with seal); lint-free cloth, tweezers or a thin pick (supplied by customer; for installation of O-Rings and drive tube). Clean all metal components with an approved solvent, including all gasket and O-Ring surfaces. Place metal components and all spare seal components on a clean dry surface.

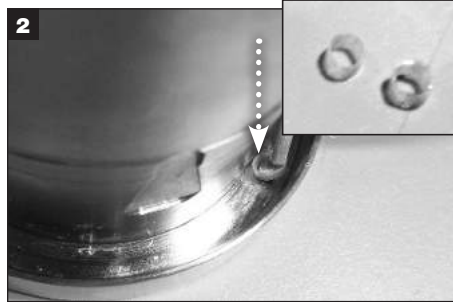

Pick up the drive tubes with tweezers or a thin pick and install onto each of the lugs in the sleeve counter bore. Ensure the drive tube is fully seated on the lug (it will bottom out).

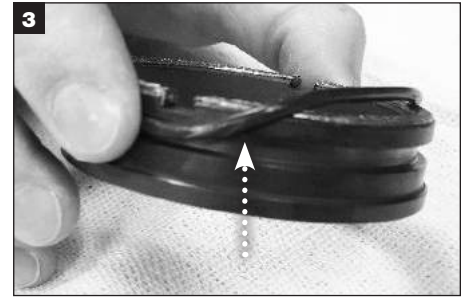

Apply a thin film of **white** grease to the rotary O-Ring (W) and install into the groove on the outer diameter of the rotary face. Ensure cushions are on the back of the rotary face. **IMPORTANT: rotary seal ring in the bag marked ROTARY INBOARD MUST be installed on the sleeve (see step 4).**

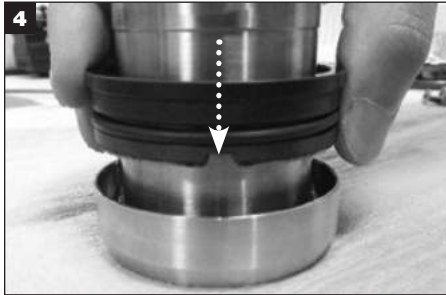

Align the mark on the rotary face with the notch on the sleeve. Slide the rotary face down to the sleeve and gently compress until it is seated. The sleeve drive lugs should engage the slots on the rotary face. **CAUTION: Do not compress drive tube.**

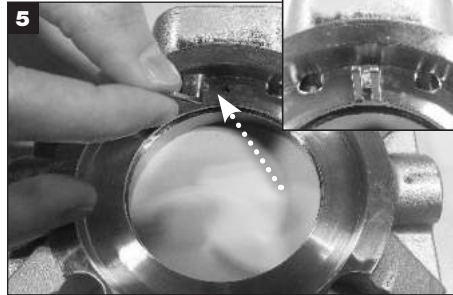

Insert the drive assembly into the gland pin hole. Ensure all surfaces are clean and free of debris.

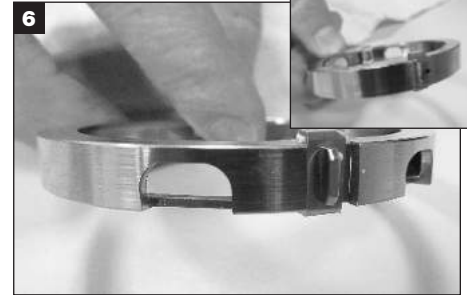

Apply a thin film of grease to the drive channel clip\* and drive channel flow deflector. Install the drive channel flow deflector in the slot between the two cutaways. Install the drive channel clip(s) in the remaining slot(s). \*NOTE: Seal sizes 25 mm – 65 mm (1.000" – 2.625") use 1 clip; 70 mm – 120 mm (2.750" – 4.750") use 3 clips.

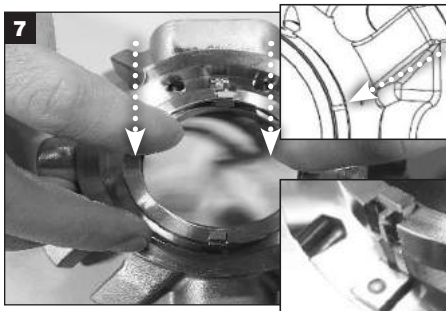

Insert the drive channel assembly into the gland, with open drive slots facing down, engaging the flow deflector into the drive assembly anti-rotation lug, the dimple on the gland will align with the mark on the outside of the drive channel.

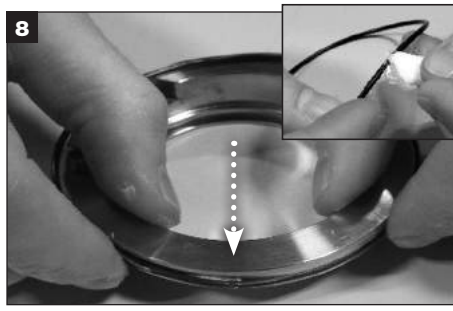

Apply a thin film of grease to the adapter O-ring (Z) and install on outside diameter of adapter plate.

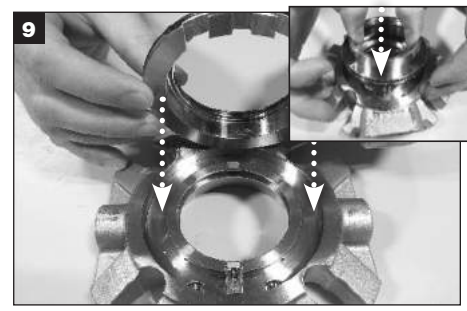

Align the adapter slots with the slots in the drive channel, engaging assembly and seat the adapter plate. **IMPORTANT: Adapter surface must be below gland surface to be fully seated and installed.**

## 9.0 SEAL REBUILD cont.

### 9.1.2 Seal Assembly cont.

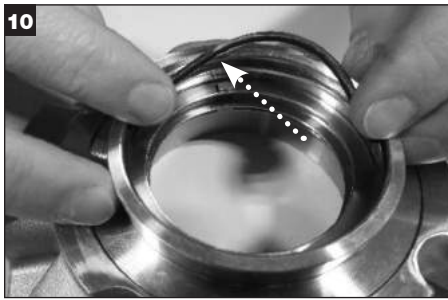

Apply a thin film of grease to the stationary O-Ring (X) and install in the inside diameter groove in the adapter.

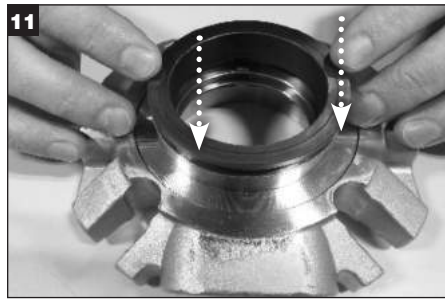

Align the slots in one stationary seal ring with the anti-rotation channel clips and flow deflector, and carefully press into place. Ensure that the seal ring is fully seated.



Carefully invert the gland and place on a clean cloth to protect the inboard sealing surface. Apply a thin film of grease to the remaining stationary O-Ring (X) and install in the inside diameter groove in the gland.



Align the slots in the remaining stationary seal ring with the anti-rotation channel clips and flow deflector and carefully press into place. Ensure that the seal ring is fully seated.

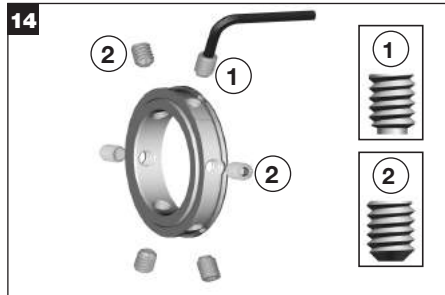

Install the 1/4 dog set screws ① into the screw holes marked with a dimple on the outside diameter of the lock ring. Install the cup point set screws ② into the remaining holes in the lock ring.



**IMPORTANT:** The set screws should not protrude into the inner diameter of the lock ring prior to installing onto the seal sleeve.



Apply a thin film of grease to the lock ring O-Ring (Y) and insert it into the inside diameter lock ring groove.

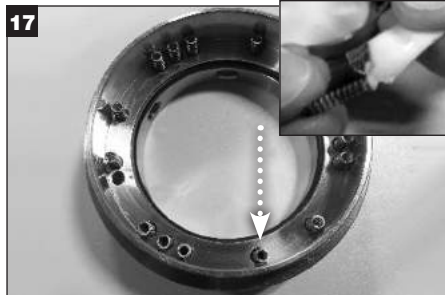

Apply a small amount of grease to one end of each spring and insert into the unmarked holes in the lock ring. **CAUTION: DO NOT install springs into the marked holes intended for the follower plate pins.**



Pick up the drive tube (use tweezers if necessary) and install onto each of the lugs in the follower assembly. Ensure the drive tube are fully seated on the lugs.

## 9.0 SEAL REBUILD cont.

### 9.1.2 Seal Assembly cont.



Align the pins in the follower assembly with the marked holes in the lock ring and press to seat into position.



Apply a thin film of grease to the rotary O-Ring (W) and install it into the groove on the outside diameter of the outboard rotary seal ring.



Align the drive slots in the rotary seal ring with the follower lugs; press gently on the rotary seal ring to seat into position in the lock ring.  
**CAUTION: Do not compress drive tube.**



Clean all seal face surfaces with a clean cloth and approved solvent prior to final assembly of components.

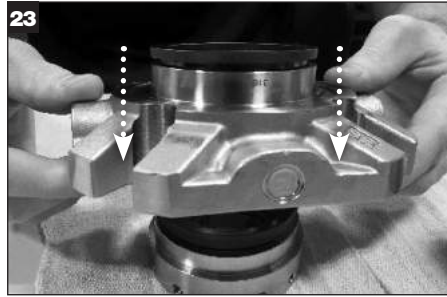

Place the gland over the lock ring assembly, Chesterton marking facing down, aligning the stationary seal ring face with the rotary seal ring face.

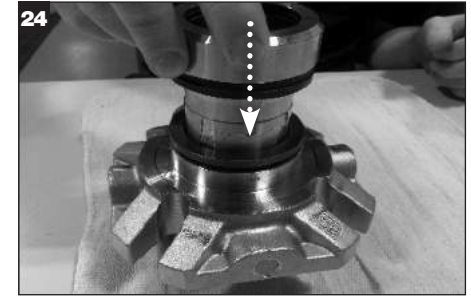

Invert the sleeve assembly, holding around the outside diameter of the rotary seal ring, and slide it into the gland and lock ring assemblies.  
**IMPORTANT: The notch on the end of the sleeve should be aligned with the three vertical dots on the lock ring outside diameter when properly installed.**



Hold the entire seal assembly and carefully invert it, and place on a clean work surface. Press firmly on the top of the lock ring and engage the 1/4 dog set screws into the small holes in the sleeve. Tighten 1/4 dog screws evenly to keep lock ring centered properly with the sleeve. **CAUTION: DO NOT deflect sleeve by overtightening the 1/4 dog point screws. The 1/4 dog set screws must not protrude into the sleeve inside diameter.**

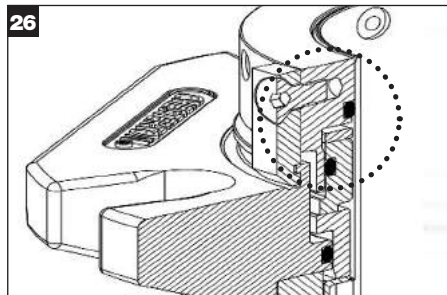

Install the centering clips by engaging the slot in the clips with the lip. Press down on the top of the gland to compress the assembly and turn each centering clip to engage the groove on the top of the gland and hand-tighten the centering clip flat head screw. Repeat this step for all centering clips. Retighten with a torque wrench:  
**Sizes 25 mm – 65 mm (1.000" – 2.625")**  
to 4,5 Nm (40 in-lbs.)  
**Sizes 70 mm – 120 mm (2.750" – 4.750")**  
to 7,8 Nm (70 in-lbs.)



Install the stuffing box gasket in the gland recess.

## 9.0 SEAL REBUILD cont.

---

### 9.1.2 Seal Assembly cont.

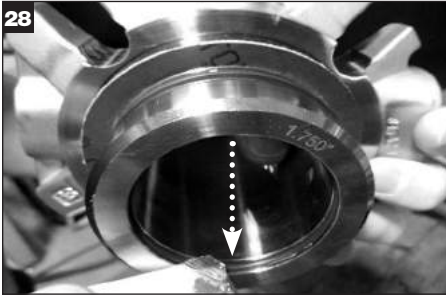

Apply a thin film of grease to the shaft O-Ring (V) and insert into the groove in the sleeve inside diameter.



The seal is ready for installation.

## 10.0 MECHANICAL SEAL RETURNS AND HAZARD COMMUNICATION REQUIREMENTS

---

Any mechanical seal returned to Chesterton that has been in operation, must comply with our Hazard Communication requirements. Please go to our web page at [chesterton.com/Mechanical\\_Seal>Returns](http://chesterton.com/Mechanical_Seal>Returns) to obtain information required for returning seals for repair or seal analysis.



DISTRIBUTED BY:

Chesterton ISO certificates available on [chesterton.com/corporate/iso](http://chesterton.com/corporate/iso)

860 Salem Street  
Groveland, MA 01834 USA  
Telephone: +1 781-438-7000 Fax: 978-469-6528  
[chesterton.com](http://chesterton.com)

© 2019 A.W. Chesterton Company.  
® Registered trademark owned by A.W. Chesterton Company  
in USA and other countries.

FORM NO. EN036794 REV 1

06/19